

Dimensions Millimeters (Inches)

**10 Size Cavity for Dual
 Check and Pilot Piston**

*For Check Valves Use 2
 CVH103P***

For Pilot Piston Use

- 717917 No Seal
- 717917N Buna-N

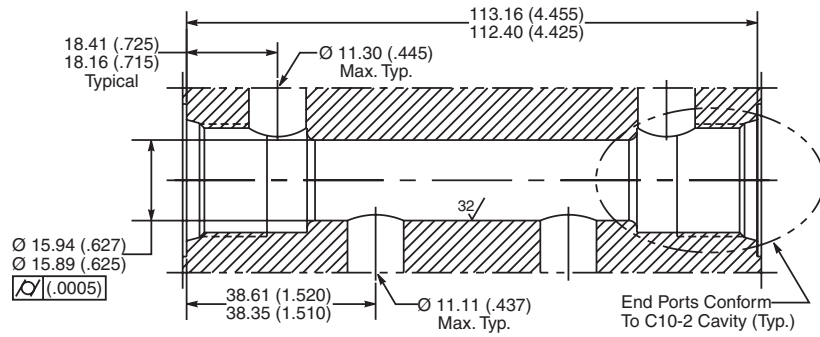

CV
Check Valves
SH
Shuttle Valves
LM
Load/Motor Controls
FC
Flow Controls
PC
Pressure Controls
LE
Logic Elements
DC
Directional Controls
MV
Manual Valves
SV
Solenoid Valves
PV
Proportional Valves
CE
Coils & Electronics
CB
Cartrpak Bodies
BC
Bodies & Cavities
TD
Technical Data